

Model 2455H-ER Five-Axis Electro-Hydraulic Flight Motion Simulator (FMS)

STANDARD FEATURES

- Position Accuracy: ± 10 arc sec
- Inter-axis Orthogonality: 30 arc sec
- Axes intersection: ± 0.02 " (± 0.5 mm)
- Rate Accuracy: $\pm 0.01\%$
- Roll axis rates up to 20 Hz (1200 RPM)
- Rack-mounted AERO 4000 Digital Controller
 - Front panel display of status and data
 - Local and remote operation
 - Trapezoidal velocity profiles (in rate mode) with programmable velocity and acceleration
 - Sinusoidal motion generator, with programmable amplitude and frequency
 - Profile mode for position, velocity, and flight (PVA) commands
 - Programmable analog inputs and outputs

DESCRIPTION

The 2455H-ER extends the capabilities of Ideal's three-axis FMS systems for hardware-in-the-loop (HWIL) seeker/guidance testing, to include target motion simulation. The inner target axis can accommodate an infra-red scene projector. Extremely efficient hydraulic actuators allow high system utilization – such as Monte Carlo-type test scenarios – on a time-continuous basis. As with our three-axis FMS systems, Ideal's flexible AERO 4000 Controller affords real-time motion control via several industry-standard high-speed interfaces. The 2455H-ER features a direct-drive DC brushless motor for the innermost (Roll) axis, high-

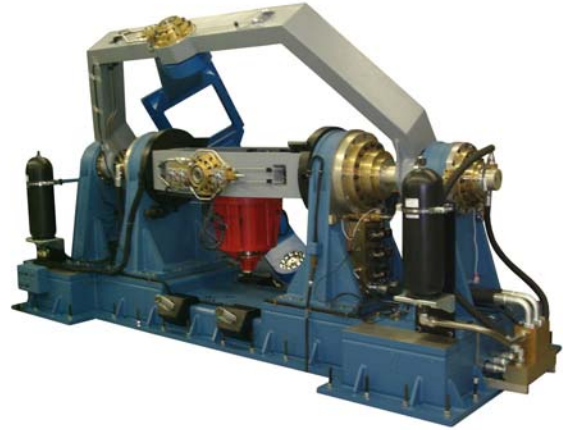

performance hydraulic vane actuators on the remaining four axes, and precision optical encoders on all axes. The AERO 4000 digital signal processor-based (DSP) controller provides accurate and reliable motion control. The user can operate the FMS from the AERO 4000 Graphic User Interface for local control, or remotely via a computer interface. It affords easy operation, and can accommodate the Ideal Aerosmith Table Language (ATL) for remote operation. The AERO 4000 controller comes standard with IEEE-488, RS-232, and Ethernet communication interfaces.

OPTIONS

- Various slip ring packages or wire wrap configurations
- Systran Corporation SCRAMNet or VMIC shared-memory interfaces

For more detailed information, contact Ideal to request a Specification Document.

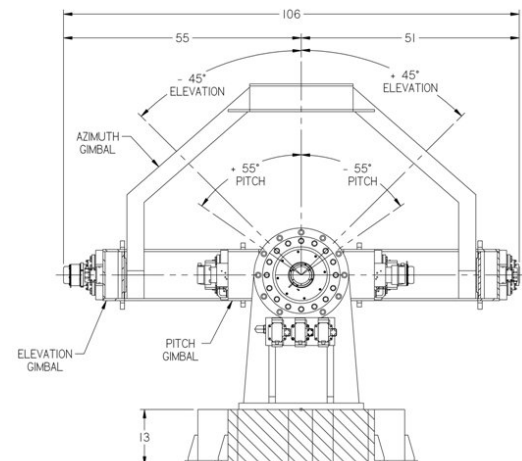
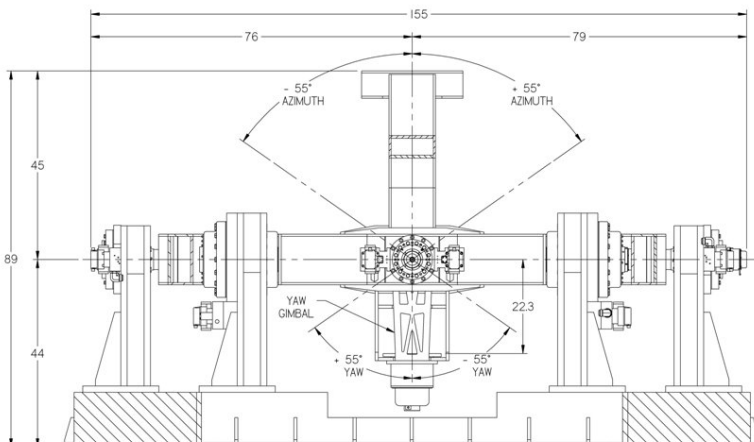

Performance Specifications					
	Inner (Roll)	Middle (Yaw)	Out (Pitch)	Inner Target (Azimuth)	Outer Target (Elevation)
Rotational Freedom Options	Unlimited	±50	±50	±50	±45
Positioning					
• Accuracy, arc sec (deg)	±10 (±0.0028)	±10 (±0.0028)	±10 (±0.0028)	±10 (±0.0028)	±10 (±0.0028)
• Repeatability, arc sec (deg)	±5 (±0.0014)	±5 (±0.0014)	±5 (±0.0014)	±5 (±0.0014)	±5 (±0.0014)
• Resolution, deg	0.0001	0.0001	0.0001	0.0001	0.0001
Rate					
• Maximum, deg/sec	±7200	±400	±400	±100	±100
• Minimum, deg/sec	±0.001	±0.001	±0.001	±0.001	±0.001
• Display Resolution, deg/sec	±0.001	±0.001	±0.001	±0.001	±0.001
• Accuracy, % ± Resolution	±0.01 (measured over 360° of travel)	±0.02 (measured over 90° of travel)	±0.02 (measured over 90° of travel)	±0.02 (measured over 90° of travel)	±0.02 (measured over 90° of travel)
Acceleration, max., deg/sec² (sinusoidal move)	20,000	15,000	15,000	1,200	1,200
Bandwidth, -3dB, (with nominal payload)	45	35	35	10	10

*Values listed are maximum values and are dependent upon system configuration. Performance parameters may vary between various configurations of the Model 2455H-ER.

System Physical Configuration	
Roll plate	The roll plate has a standard size of 14-inch (350 mm) diameter. Custom tabletop and interface patterns available upon request.
Roll plate Connectors	MS-type connector(s), located on roll plate periphery
Number of User Lines	Standard slip ring package is 48 lines at 5 amps per line. Custom packages are available.
Test Load	
• Nominal	44 lbs (20kg), 2.75" (70 mm) diameter, 24" (600mm) long
• Maximum	132 lbs (60kg), 14" (350 mm) diameter, 24" (600mm) long
AERO 4000 Digital Controller	Request an AERO 4000 Controller data sheet for more information.
• Type & Configuration	AERO 4000 Test Table Controller configured in a 19-inch Cabinet
• Communication Interfaces	IEEE-488, RS-232 and Ethernet ports available to user. Systran Corporation SCRAMNet or VMIC shared-memory interfaces available as options.

For additional information or special requirements, contact Ideal Aerosmith. Specifications subject to change without notice. Please call for pricing.

Rev C